



DISCONTINUED

Q-SERIES® Optical

QFOT 1550nm Series Broadcast Transmitter

INSTALLATION & OPERATION MANUAL

Although every effort has been taken to ensure the accuracy of this document it may be necessary, without notice, to make amendments or correct omissions. Specifications subject to change without notice.

SignalOn® Series, MAXNET®, HFC Enhance®, PCI Filters®, Q-Series® & FiberLinx® are registered trademarks of ATX in the United States and/or other countries. SMACSM is a service mark of ATX in the United States and/or other countries. Products or features contained herein may be covered by one or more U.S. or foreign patents. Other non-ATX product and company names in this manual are the property of their respective companies.

TABLE OF CONTENTS

	Page
1. <u>PREFACE</u>	1-1
2. <u>OVERVIEW</u>	2-1
3. <u>FEATURES</u>	3-1
4. <u>FUNCTIONAL DIAGRAM</u>	4-1
5. <u>SPECIFICATIONS</u>	5-1
5.1. <u>Link Test Condition</u>	5-1
5.2. <u>Specifications Table</u>	5-1
6. <u>FUNCTION GUIDE</u>	6-1
6.1. <u>Front Panel Guide</u>	6-1
6.2. <u>Rear Panel Guide</u>	6-1
6.3. <u>Parameter Display</u>	6-2
6.4. <u>Alarm Indication</u>	6-2
7. <u>INSTALLATION & ADJUSTMENT</u>	7-1
7.1. <u>Opening the Cover</u>	7-1
7.2. <u>Supplies & Tools</u>	7-1
7.3. <u>Installation</u>	7-1
8. <u>CLEANING & MAINTENANCE</u>	8-1
9. <u>AFTER-SALE CUSTOMER SERVICE</u>	9-1
10. <u>TROUBLESHOOTING</u>	10-1
11. <u>SERVICE & SUPPORT</u>	11-1
11.1. <u>Contact ATX Networks</u>	11-1
11.2. <u>Warranty Information</u>	11-1

This page left intentionally blank.

PREFACE

1. Preface

This manual is designed for the QFOT1550 series 1550nm broadcast transmitter along with a detailed description of the product features, specifications, installation, adjustments and troubleshooting. To install this transmitter successfully and use it safely, users must read the manual carefully before installation, and perform their installation and adjustments according to this manual. Otherwise, some practices may lead to property damage or personal injury. Please contact ATX Networks if you have any questions.

Important User Information

- **Caution:** There are invisible laser beams from Fiber output ports, which may cause permanent injury to skin or eyes.
- Ground first before turning on the power (grounding resistance should be less than 4 Ohm), so as to prevent laser and user from static damage.
- UPS power supply and an air conditioned environment are highly recommended for stable and long-time transmitter operation.

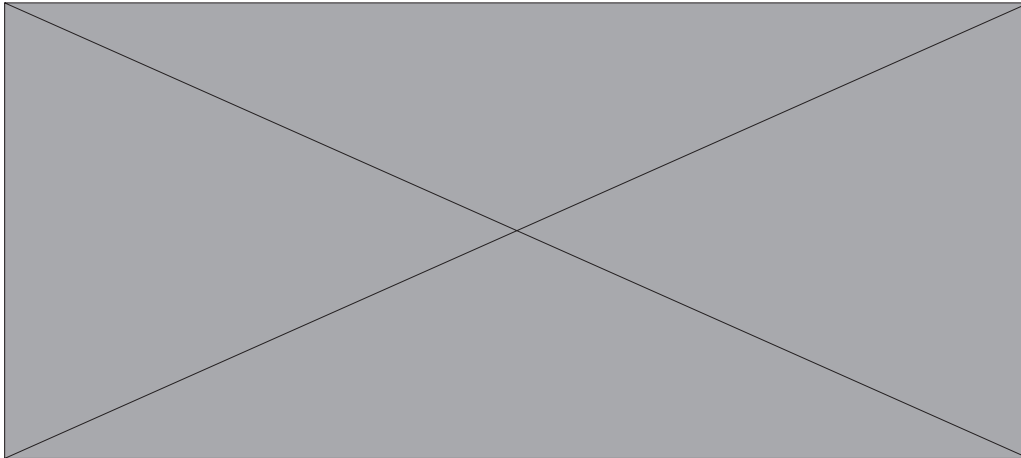

This page left intentionally blank.

OVERVIEW

2. Overview

The QFOT1550 is a direct modulation 1550nm DFB laser transmitter delivering TV signals, digital TV signals, telephone voice signals and data signals over long distance fiber cable for CATV networks. The product utilizes a high performance cooled DFB laser as the light source, along with RF powered digital automatic process techniques and an RF pre-distortion circuit. At the same time, a built-in microprocessor monitoring system automatically ensures the excellent performance of this transmitter.

This page left intentionally blank.

FEATURES

3. Features

- High performance DFB laser with narrow spectrum and good linearity.
- RF powered digital automatic processing technology.
- Excellent pre-distortion technology leads to the improved CTB, CSO and C/N.
- Built-in microprocessor controls laser and RF performance.
- Front panel VFD screen displays the transmitter status.
- 19" 1RU standard rack with RS485 and RS232 ports for optional remote monitoring.
- Optional Ethernet port for SNMP management.

This page left intentionally blank.

FUNCTIONAL DIAGRAM

4. Functional Diagram

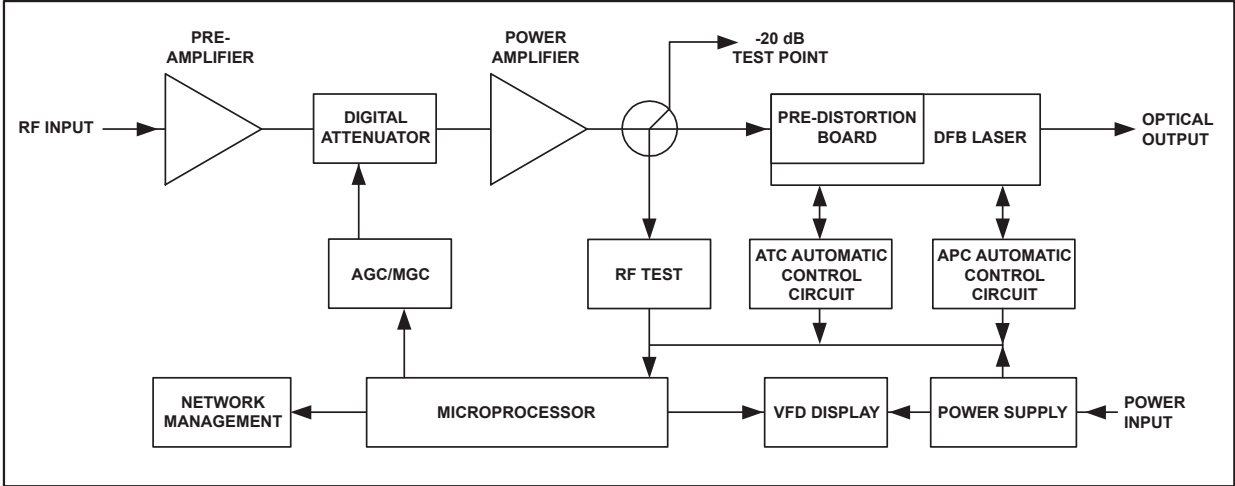

This page left intentionally blank.

SPECIFICATIONS

5. Specifications

5.1. Link Test Condition

Test Condition:

Test link consists of the QFOT1550 transmitter, 10 km standard fiber, attenuator and standard optical receiver. Input RF channels are 59 PAL-D channels (equivalent to 77 NTSC channels). The optical receiver input power is -1dBm.

5.2. Specifications Table

SPECIFICATIONS	QFOT1550-D-10
OPTICAL POWER	10mW
OPTICAL LINK PATH LOSS	11 dB
OPTICAL WAVELENGTH	1555nm +/- 10
TYPE OF LASER	14-pin Cooled DFB Laser in Butterfly Package with Isolator
OPTICAL MODULATION MODE	Direct Modulation
OPTICAL CONNECTOR TYPE	SC/APC
FREQUENCY RANGE	50-870 MHz (1000 MHz Optional)
RF INPUT LEVEL	15-25 dBmV
FLATNESS IN BAND	+/- 0.75 dB
RF INPUT IMPEDANCE	75 Ω
INPUT REFLECTION LOSS	≥ 16 dB (50-870/1000) MHz
C/COMP. TR. BT.	≥ 65 dB
C/COMP. 2nd ORD.	≥ 59 dB
CARRIER-TO-NOISE RATIO	≥ 51 dB
AGC CONTROL RANGE	0-15 dB
MGC CONTROL RANGE	0-15 dB
POWER VOLTAGE	100-240 VAC (50/60 Hz)
POWER CONSUMPTION	15W
OPERATION TEMPERATURE	0°C to +50°C (+32°F to +122°F)
STORE TEMPERATURE	-40°C to +85°C (-40°F to +185°F)
RELATIVE HUMIDITY	Max 95% Non-condensing
DIMENSIONS	1.75"H x 19.0"W x 15.0"D (4.45H x 48.26W x 38.1D cm)
WEIGHT	11.0 lbs (5.0 kg)

This page left intentionally blank.

FUNCTION GUIDE

6. Function Guide

6.1. Front Panel Guide

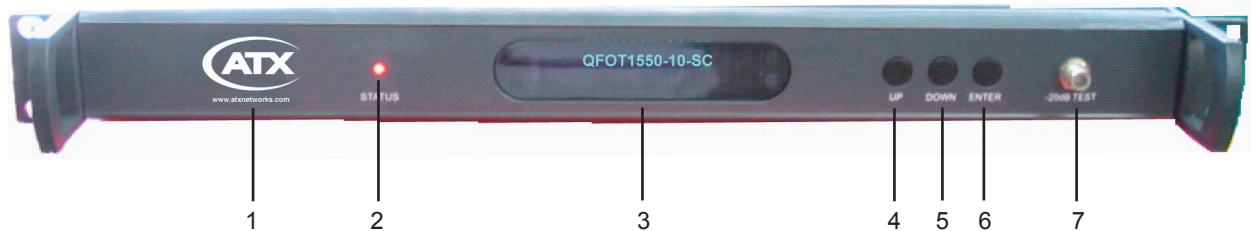

Front View

- 1 **ATX Trademark**
- 2 **LED Status Indicator:** Green light: normal; Red light: warning. Check VFD message to troubleshoot problem.
- 3 **VFD Monitor:** Displays each status parameter, product model, serial number and other information about this transmitter.
- 4 **UP Button:** Scroll the VFD display UP, or increase setting value.
- 5 **Down Button:** Scroll the VFD display DOWN, or decrease setting value.
- 6 **Enter Button:** MGC/AGC mode and MGC Attenuation Number mode select.
NOTE: At “AGC Status”, pressing “Enter” would switch to “MGC Status”; at “MGC Status”, pressing “Enter” would switch to “AGC Status”. There are the following two ways to change the RF modulation level to the laser.
 At “AGC Status”, press the UP or DOWN button until the VFD displays “**MOD LEVEL=XXdBmV**”, then press the “Enter” button to select. After selecting, the VFD will display “**MOD LEVEL=XXdBmV**” and “**Please install...**”. At this point the user can change the modulation level in 1 dB increments by pressing the UP or DOWN buttons. Once you have selected the desired modulation level, press ENTER again to make it effective. At that time the VFD will display “**MOD LEVEL=XXdBmV**” and transmitter will shift back to AGC mode. For instance, if user’s ideal Modulating level is **38dBmV**, VFD would display “**MOD LEVEL= 38dBmV**” after operations shown above. Please consult an ATX Networks engineer for help with this feature.
 At “MGC Status”, press the UP or DOWN button until the VFD displays “**MGC ATT=XXdB**”, then press the “Enter” button to select. After selecting, the VFD will display “**MGC ATT=XXdBmV**” and “**Please install...**”. At this point the user can change the modulation level in 1 dB increments by pressing the UP or DOWN buttons. For instance, the MGC ATT decrease 3 dB will increase the MOD LEVEL by 3 dB. Once you have selected the desired MGC ATT value, press ENTER again to make it effective.
NOTES: At “AGC Status”, the total RF power to the laser is locked, not depending on the input RF level and channel number. At “MGC Status”, the total RF power to the laser may vary with the input RF level and channel number. The default control mode of the QFOT1550 transmitter is AGC.
- 7 **RF Input Test Port:** Standard 75 Ohm style F-style test port for RF signal on-line test. Level tested from this port is 20 dB lower than the actual RF drive level to the laser.

6.2. Rear Panel Guide

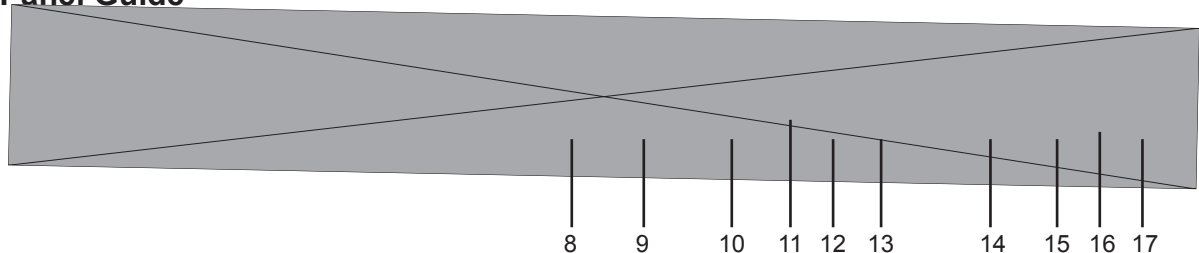

Rear View

- 8 **RF Input Port:** Standard 75 Ohm American style F port, used for connecting RF signal and the equipment. Level in this input port must be at the range of 15-25dBmV. Too high level may damage laser. **Optimum input level is 17dBmV.**
***The input level above 17dBmV may damage laser. Please consult factory!**

- 9 **Optical Signal Output:** Optical signal output port, SC/APC, or optional FC/APC connector. There are invisible laser emissions from Fiber output when laser is active!
*It would be dangerous to point this port toward the human body especially eyes when equipment is energized!
- 10 **RS-232 Standard Network Management Port (optional):** Use for connecting equipment with RS-232 port in network management server.
- 11 **Network Management Indicator**
- 12 **RS-485 Standard Network Management Port (optional):** Use for connecting equipment with RS-485 port on network management server.
- 13 **LAN Network Management Port:** Use for connecting transmitter with Ethernet-basing network management server. (Contact factory for this option)
- 14 **Power In:** AC power connection.
- 15 **Fuse:** AC fuse
- 16 **AC Power Switch:** Turn ON or turn OFF the power.
- 17 **Case Grounding Nut:** Provided for optionally connecting the transmitter to ground.

6.3. Parameter Display

6.3.1. Turning On Power Display

When first turning on the power, the VFD will display “Initialize...” for 2 seconds and the buzzer will briefly tweet one time indicating that the transmitter has initialized successfully.

6.3.2. Status Display

After the transmitter has been powered ON and initialized, pressing the UP or DOWN button on the front panel will scroll the VFD to display in turn the following:

- 1) “Welcome to ATX”: trademark
- 2) **AGC Status (Press “Enter” will switch to “MGC Status”, 2nd “Enter” will go back to AGC)**
- 3) “S/N: xxxx-xx-xxxx”: equipment series number
- 4) “MOD LEVEL= XXdBmV”: modulating level value
(Press “Enter” at “AGC Status” will increase or decrease the RF level to the laser)
- 5) “AGC ATT= XXdB”: attenuation value at “AGC Status”
(Press “Enter” at “MGC ATT=XXdB” will increase or decrease the RF level to the laser)
- 6) “INPUT RF= XXdBmV”: RF input level
- 7) “BIAS= XX mA”: bias current of the laser
- 8) “TEMP=XX.X °C”: internal temperature value of the laser
- 9) “POWER=XX.X mW”: output power, unit **mW**
- 10) “QFOT1550-D-XX-SC”: module name, **SC** indicated output fiber connector

6.4. Alarm Indication

Display Message	Alarm Status	System Indication
Warning...!!! Input RF is low	Input RF is too low	• <i>Status indicator</i> red light flashes
Warning... !!! Input RF is high	Input RF is too high	• <i>Status indicator</i> red light flashes

INSTALLATION & ADJUSTMENT

7. Installation & Adjustment

7.1. Opening the Cover

- 7.1.1. Inspect the package. If the packaging has been damaged, or shows signs of water damage, please contact the freight company or contact ATX.
- 7.1.2. After unpacking, check the equipment and accessories according to packing list. If there is any question, please contact ATX.
- 7.1.3. If you think equipment has been damaged, don't turn on the power. This will avoid worse damage. Please contact ATX.

7.2. Supplies & Tools

An optical power meter.

A digital multimeter.

A Cable TV RF meter or spectrum analyzer.

A standard fiber test jumper (FC/APC or SC/APC).

Denatured or 99% pure isopropyl alcohol and lint-free fiber optic cleaning wipes.

7.3. Installation

- a) Mount the equipment in the rack and ground the case.
- b) Check input voltage using a digital multimeter in accordance with power requirement. Then turn on power.
- c) Check message on the VFD and status of the front panel LED indicator. Push the **UP** and **DOWN** button to check each parameter, insuring that the transmitter is operating normally. (If there is no RF input, the red LED will flash, and the VFD will display "**input RF is low**".)
- d) Connect standard fiber test cable to the transmitter's optical signal output. Measure the output optical power and confirm that the output optical power is the same as the value displayed on the VFD. (When measuring the optical power, make sure that optical power meter is set for 1550nm wavelength and that fiber test jumper is clean.)
- e) Measure the input RF signal level with a Cable TV meter or a spectrum analyzer, making sure that input RF signal is in the range of 15-25dBmV (optimum value 17dBmV). At this time, you can now connect the RF signal to the RF signal input port of the equipment. The front panel LED turns to green and VFD displays RF input value as "**RF INPUT = XXdBmV**".

The internal RF power detector is calibrated for 77 analog NTSC channels, so the displayed value may not be correct, depending upon your actual channel plan. It is possible to correct the displayed value to read your measured RF level by pressing the UP or DOWN button and scroll the VFD until it displays "**RF LEVEL=XXdBmV**", then press ENTER. The VFD will now display "**MOD LEVEL=XXdBmV**" and "**Please install...**", and the user can now set the RF input level in **1 dBmV** increments by pressing the UP or DOWN buttons. When the displayed value is equal to your tested value, press ENTER to make it effective, and at that time the VFD will display "**RF LEVEL=XXdBmV**". For instance, if real RF input level is **20dBmV**, VFD would display "**RF LEVEL= 20dBmV**" after operations shown above.

- f) Re-measure optical output power, make sure that optical output power is normal, remove standard fiber test jumper and optical power meter, connect the equipment to network and end the installation.

This page left intentionally blank.

CLEANING & MAINTENANCE

8. Cleaning & Maintenance

Each fiber connector can become contaminated by dust or dirt in the operation process, which can result in increased optical link loss, or a degraded carrier-to-noise ratio. If you find that the optical receiver power or RF output level of the optical receiver has declined, you should clean and maintain the fiber active connector. The clean methods are recommended below:

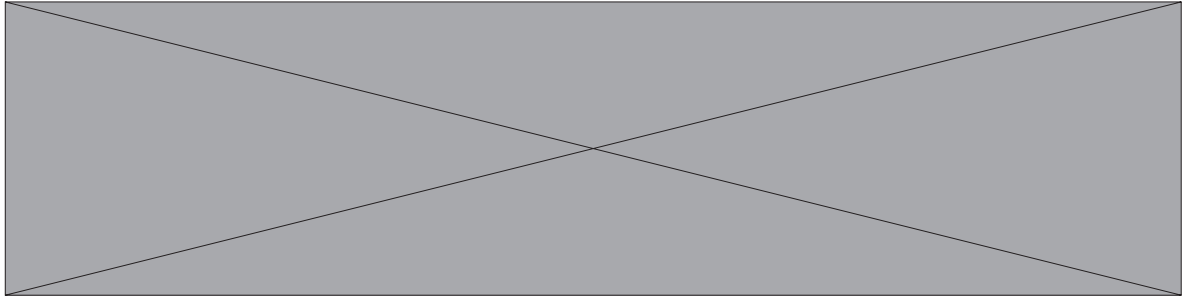

- a) Carefully unplug or unscrew the active fiber connector from the adapter, while being careful to avoid aiming the fiber connector at any human body or eye.
- b) Use a lint-free fiber optic wipe saturated with alcohol to clean the connector carefully. Once finished, still wait 1-2 minutes until active connector surface is air dried.
- c) When the cleaned optical active connector is reconnected to the adapter, please do not over-tighten or force the connector, to avoid damage to the ceramic ferrule.
- d) The fiber active connector should be cleaned on both ends. If optical power is still low after cleaning, cleaning the other end of the fiber is recommended. If the optical power is still low after cleaning both ends, it is recommended that you clean the inner adaptor. (Take care of the fiber when disassembling the adaptor)
- e) Use compressed air or a lint-free wipe to wash the adaptor carefully. When using compressed air, aim the nozzle at the ceramic ferrule of the adaptor, cleaning the ferrule with compressed air.

NOTES:

1. Avoid aiming the optical output or fiber connector at the human body or eyes.
2. Assemble the fiber adaptor gently and carefully to prevent damage to the ceramic ferrule inside the adaptor.

This page left intentionally blank.

AFTER-SALE CUSTOMER SERVICE

9. After-sale Customer Service

- a) Our promises: One year free trouble fixing service and life-long customer service (1 year free guarantee time starts from the date indicated on products S/N attached to side of products).
- b) If the equipment has failed, please contact ATX immediately.
- c) Do not attempt to repair the problem without the assistance of an ATX technician.
- d) **NOTE:** There are adhesive tape seals on both sides of the case. Any unauthorized removal of this tape seal by the user will void the 1 year warranty.

This page left intentionally blank.

TROUBLESHOOTING

10. Troubleshooting

SYMPTOM	FAULT	ACTION
No VFD or LED display after turning on the power.	No input power or a problem with the internal switching power supply.	Check input AC voltage to the power supply (AC90V-250V), if the voltage is normal, usually the cause is the internal switching power supply, contact ATX.
After turning on power, VFD monitor and LED are normal, but optical output power is low.	<ol style="list-style-type: none"> 1. Check jumper quality. 2. Contaminated optical active connector or adapter. 3. Damaged ceramic ferrule in adapter. 	<ol style="list-style-type: none"> 1. Swap to a good test jumper. 2. Clean contaminated fiber active connector or adapter. 3. Swap the damaged adapter.
After connecting to network, all TV channels have obvious noise point.	<ol style="list-style-type: none"> 1. Low received optical power, causing poor C/N. 2. RF input level too low for sufficient laser modulation. 3. System link path C/N too low. 4. Back-reflection from bad or dirty optical connectors. 	<ol style="list-style-type: none"> 1. Clean fiber active connector or adapter (Chapter 8 Cleaning and Maintenance). 2. Check RF input levels to transmitter. (15-25dBmV). 3. Check link loss. 4. Use only angled (SC/APC) optical connectors or fusion splice where necessary.
After connecting to network, only some TV channels have a degraded SNR.	Some channels SNR too low.	<p>Check the individual channel signal C/N or SNR.</p> <p>Check the flatness of the RF input signal.</p>
After connecting to network, some TV channels have obvious ripple, beats, lines, or distortions.	<ol style="list-style-type: none"> 1. Optical input power to receiver too high. 2. RF modulation too high. 3. RF input drive to transmitter too high. 	<ol style="list-style-type: none"> 1. Check input power at optical receiver and pad if necessary. 2. Check optical transmitter modulation level parameter, and readjust if too high. 3. Make sure the RF input level is within the range (15-25dBmV).

This page left intentionally blank.

SERVICE & SUPPORT

11. Service & Support

11.1. Contact ATX Networks

Please contact ATX Technical Support for assistance with any ATX products. Please contact ATX Customer Service to obtain a valid RMA number for any ATX products that require service and are in or out-of-warranty before returning a failed module to the factory.

RF Products

(MAXNET, SignalOn, HFC Enhance, PCI Filters, Q-Series, SCN, SMAC, FiberLinx)

TECHNICAL SUPPORT

Tel: (905) 428-6068 – press *3 then press 2
Toll Free: (800) 565-7488 – press *3 then press 2 (USA & Canada only)
Email: rfsupport@atxnetworks.com

CUSTOMER SERVICE

ATX Networks
1-501 Clements Road West
Ajax, ON L1S 7H4 Canada

Tel: (905) 428-6068 – press *1
Toll Free: (800) 565-7488 – press *1 (USA & Canada only)
Fax: (905) 427-1964
Toll Free Fax: (866) 427-1964 (USA & Canada only)
Email: support@atxnetworks.com
Web: www.atxnetworks.com

11.2. Warranty Information

All of ATX Networks' products have a 1-year warranty that covers manufacturer's defects or failures.



© 2018 ATX Networks
Printed in Canada
Information in this document is subject to change without notice.
Rev. 07/18 (ANW0788)



ATX Networks
1-501 Clements Road West, Ajax, ON L1S 7H4 Canada
Tel: 905.428.6068 | Toll Free: 800.565.7488 | support@atxnetworks.com

www.atxnetworks.com