



# SignalOn<sup>®</sup> Series

D3.1/CCAP™  
Compliant

1.2 GHz

## Chassis Cable Management & Power Supply Products

INSTALLATION & OPERATION MANUAL

Although every effort has been taken to ensure the accuracy of this document it may be necessary, without notice, to make amendments or correct omissions. Specifications subject to change without notice.

SignalOn® Series is a registered trademark of ATX in the United States and/or other countries. Products or features contained herein may be covered by one or more U.S. or foreign patents. Other non-ATX product and company names in this manual are the property of their respective companies.

*ATX Confidential & Proprietary*

# TABLE OF CONTENTS

	Page
<b><u>Admonishments</u></b> .....	iii
<b><u>General Safety Precautions</u></b> .....	iii
<b><u>Certification</u></b> .....	iii
<b><u>FCC Compliance Statement</u></b> .....	iii
<b><u>Standards</u></b> .....	iv
<b><u>List of Acronyms and Abbreviations</u></b> .....	iv
<b>1. GENERAL</b> .....	<b>1-1</b>
<b>2. PRODUCT DESCRIPTION</b> .....	<b>2-1</b>
2.1. <u>Chassis</u> .....	2-2
2.2. <u>Power Supply</u> .....	2-3
<b>3. PLANNING</b> .....	<b>3-1</b>
3.1. <u>Cooling Considerations</u> .....	3-1
<b>4. INSTALLATION</b> .....	<b>4-1</b>
4.1. <u>Chassis Installation</u> .....	4-1
4.2. <u>Connect Chassis Ground</u> .....	4-2
4.3. <u>Installing Power Supply Modules in 5RU Chassis</u> .....	4-3
4.4. <u>Installing Power Supply Modules in 2RU Chassis</u> .....	4-4
4.5. <u>Install 5RU Chassis Door</u> .....	4-5
4.6. <u>Install Designation Card (5RU Chassis)</u> .....	4-6
4.7. <u>Alarm Connections</u> .....	4-6
4.8. <u>Power Connections</u> .....	4-7
<b>5. CABLE MANAGEMENT</b> .....	<b>5-1</b>
5.1. <u>5RU 20-Position Chassis Cabling</u> .....	5-1
5.2. <u>2RU 8-Position Chassis Cabling</u> .....	5-2
<b>6. OPERATING INSTRUCTIONS</b> .....	<b>6-1</b>
6.1. <u>Power Supply</u> .....	6-1
<b>7. MAINTENANCE</b> .....	<b>7-1</b>
7.1. <u>Power Supply Fan Replacement Procedure</u> .....	7-1
7.2. <u>Preventative Actions</u> .....	7-3
7.3. <u>Cooling Fan Maintenance</u> .....	7-3
<b>8. SPECIFICATIONS</b> .....	<b>8-1</b>
<b>9. SERVICE &amp; SUPPORT</b> .....	<b>9-1</b>
9.1. <u>Contact ATX Networks</u> .....	9-1
9.2. <u>Warranty Information</u> .....	9-1
9.3. <u>Safety</u> .....	9-1

# Index of Figures and Tables

## Figures

#1	<a href="#">4-Position, 1RU Chassis</a>	2-1
#2	<a href="#">8-Position, 2RU Chassis</a>	2-1
#3	<a href="#">20-Position, 5RU Chassis</a>	2-1
#4	<a href="#">2RU 8-Position Chassis Drawing</a>	2-2
#5	<a href="#">5RU 20-Position Chassis with Door Installed Drawing</a>	2-2
#6	<a href="#">100/120/240 VAC Power Supply</a>	2-3
#7	<a href="#">-48 VDC Power Supply</a>	2-4
#8	<a href="#">Recommended Fully Loaded 2RU Chassis Spacing</a>	3-2
#9	<a href="#">Recommended Fully Loaded 5RU Chassis Spacing</a>	3-2
#10	<a href="#">Installing 2RU Chassis in Rack</a>	4-1
#11	<a href="#">Installing 5RU Chassis in Rack</a>	4-2
#12	<a href="#">2RU Chassis Ground Connection (Rear View shown without Power Kit)</a>	4-2
#13	<a href="#">5RU Chassis Ground Connection (Rear View)</a>	4-3
#14	<a href="#">Power Supply Location 5RU Chassis</a>	4-3
#15	<a href="#">Power Supply Module Installation (5RU Chassis)</a>	4-4
#16	<a href="#">Power Supply Module Installation (2RU Chassis)</a>	4-5
#17	<a href="#">Door Installation (5RU Chassis)</a>	4-5
#18	<a href="#">Designation Card Installation (5RU Chassis)</a>	4-6
#19	<a href="#">Alarm Contact Connections</a>	4-6
#20	<a href="#">N-ACC-CBL-DC-DC Power Cable for N-MV48DC SignalOn -48 VDC Power Supply</a>	4-8
#21	<a href="#">+24 VDC Terminal Block Location (2RU Chassis)</a>	4-9
#22	<a href="#">+24 VDC Terminal Block Location (5RU Chassis)</a>	4-9
#23	<a href="#">Fully Loaded Chassis with 8 Forward Path Amplifiers and 2 AC Power Supplies (Power Strip Removed for Clarity)</a>	5-1
#24	<a href="#">Cable Ring Usage</a>	5-2
#25	<a href="#">2RU Chassis Cable Management Bracket</a>	5-3
#26	<a href="#">-48 VDC Power Supply</a>	6-1
#27	<a href="#">AC Power Supply (Front View)</a>	7-1
#29	<a href="#">Power Supply Fan Replacement</a>	7-2

## Tables

#1	<a href="#">Alarm Terminal Defaults</a>	4-7
#2	<a href="#">Front Panel Indicators and Test Point</a>	6-1

## Admonishments

Important safety admonishments are used throughout this manual to warn of possible hazards to persons or equipment. An admonishment identifies a possible hazard and then explains what may happen if the hazard is not avoided. The admonishments — in the form of Dangers, Warnings, and Cautions — must be followed at all times. These warnings are flagged by use of the triangular alert icon (seen below), and are listed in descending order of severity of injury or damage and likelihood of occurrence.



**Danger:** *Danger is used to indicate the presence of a hazard that **will** cause severe personal injury, death, or substantial property damage if the hazard is not avoided.*



**Warning:** *Warning is used to indicate the presence of a hazard that **can** cause severe personal injury, death, or substantial property damage if the hazard is not avoided.*



**Caution:** *Caution is used to indicate the presence of a hazard that **will** or **can** cause minor personal injury or property damage if the hazard is not avoided.*

## General Safety Precautions



**Warning:** *Never install equipment in a wet location or during a lightning storm.*



**Warning:** *Before making any connections to the chassis, verify that the power is off (fuse removed at the fuse and alarm panel) and that the plug-in module is removed from the chassis. Do not install plug-in module until after the chassis wiring is completed.*

## Certification

The SignalOn chassis and power supply products have been tested and found to comply with the requirements of UL 60950, EN 1950, and CSA 22.2 No. 0.7.

## FCC Compliance Statement

The SignalOn chassis and power supply products have been certified to comply with the requirements for class A computing devices per part 15 of the FCC regulations.



**Warning:** *This equipment generates, uses, and can radiate radio frequency energy and if not installed and used in accordance with the instruction manual, may cause interference to radio communications. It has been tested and found to comply with limits for a Class A digital device pursuant to Subpart B of Part 15 of FCC Rules, which are designed to provide reasonable protection against such interference when operated in a commercial environment. Operation of this equipment in a residential area is likely to cause interference to TV and radio reception in which case the user, at their own expense, will be required to take whatever measures may be required to correct the interference.*

*This equipment does not exceed Class A limits for radio emission for digital apparatus, set out in the radio interference regulation of the authorization methods of Industry Canada. Operation in a residential area may cause unacceptable interference to TV and radio reception requiring the owner or operator to take whatever steps are necessary to correct the interference.*

## Standards

EN55022

Limits and Methods of Measurement of Radio Interference Characteristics of Information

	Technology Equipment
ISTA+7	International Safe Transit Authority
ANSI/SCTE 06 1999	Composite Distortion Measurements
ANSI/SCTE 01 1996	“F” Port (Female Outdoor) Physical Dimensions
NCTA	Part 4 NTC REPORT No.7 Video Facility Testing
TR-TSY-000332	Reliability Prediction Procedure for Electronic Equipment

## List of Acronyms and Abbreviations

The acronyms and abbreviations used in this manual are detailed in the following list:

<b>AWG</b>	American Wire Gauge
<b>ANSI</b>	American National Standards Institute
<b>BDFB</b>	Battery Distribution Fuse Bay
<b>CATV</b>	Cable TV
<b>CPE</b>	Customer Premise Equipment
<b>CI</b>	Customer Interface
<b>FCC</b>	Federal Communications Commission
<b>GND</b>	Ground
<b>MBB</b>	Make-Before-Break
<b>MON</b>	Monitor
<b>NID</b>	Network Interface Device
<b>RCV</b>	Receive
<b>TTL</b>	Transistor-Transistor Logic
<b>XMT</b>	Transmit

# GENERAL

## 1. General

The SignalOn system is a modular system that permits high isolation combining, splitting, and amplification of headend signals in a CATV system. The system is designed to accommodate strong cable management, EMI shielding, and ease of use. This facilitates easy reconfiguration and high performance within a dynamic headend environment.

There are three SignalOn chassis. The 4-position chassis has no provisions for power and only supports passive modules. The 8- and 20-position chassis have provisions for power and support both active and passive modules.



This page left intentionally blank.



## PRODUCT DESCRIPTION

### 2. Product Description

The 4-position chassis is 1.75 inches (4.45 cm) high (1RU), designed for installation in 19-inch EIA racks. The SignalOn 4-position chassis is shown in Figure 1. Chassis mounting brackets may be moved to the front of the chassis allowing chassis to be turned around in the mounting rack. When chassis is turned around modules are installed from the rear allowing access to the connectors on the front.



Figure #1: 4-Position, 1RU Chassis

The 8-position chassis is 3.49 inches (8.86 cm) or 2 Rack Units (RU) high, designed for use in 19-inch EIA racks. The SignalOn 2RU chassis is shown in Figure 2. Optional extender brackets are available for 23-inch rack installation.



Figure #2: 8-Position, 2RU Chassis

The 20-position chassis is 8.75 inches (22.23 cm) or 5 Rack Units (RU) high, designed for use in 19-inch EIA racks. Modules are installed vertically in this chassis. The SignalOn 5RU chassis is shown in Figure 3. Optional extender brackets are available for 23-inch rack installation.



Figure #3: 20-Position, 5RU Chassis

## 2.1. Chassis

The SignalOn chassis provides configuration and connection flexibility in a CATV broadband service system. Chassis is designed to accommodate SignalOn passive modules, forward path amplifiers, and power supplies in various configurations. There are two SignalOn powered chassis available.

**NOTE:** SignalOn forward path amplifiers/power supplies require that an optional power strip/kit be installed in the chassis.

When the power option is installed the chassis may be connected directly to +24 VDC office power. If AC or –48 VDC is required, optional power supply modules may be installed in the chassis. See section [Power Connections](#) for details on cabling procedures for the power supplies. Frame ground screw terminals are located on the rear of the chassis.

**NOTE:** When installing chassis with amplifiers and power supplies, provisions must be made allowing for sufficient airflow. See section [Cooling Considerations](#) for installation recommendations.

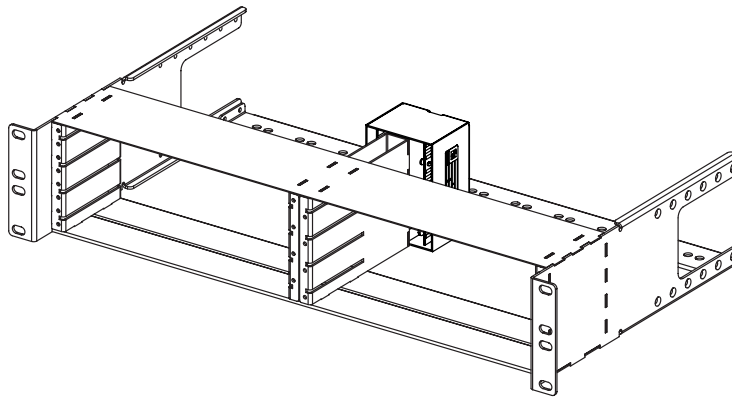

Figure #4: 2RU 8-Position Chassis Drawing

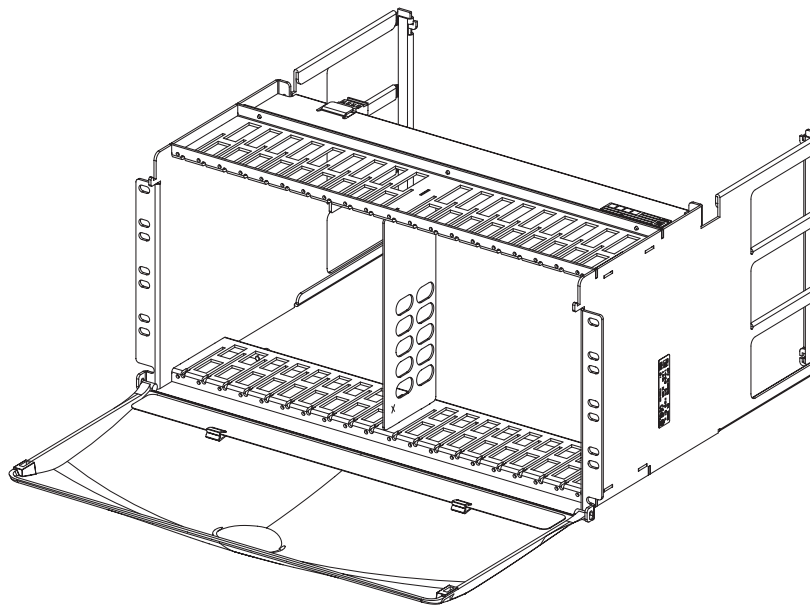

Figure #5: 5RU 20-Position Chassis with Door Installed Drawing

## 2.2. Power Supply

A 100/120/240 VAC or  $-48$  VDC to  $+24$  VDC power supply installed in the chassis may be used to provide power to active modules through the backplane. One power supply is sufficient for operation; however, two power supplies are recommended for redundant powering. When AC/DC or DC/DC power supplies are not used,  $+24$  VDC from another source may be connected directly to the chassis backplane.

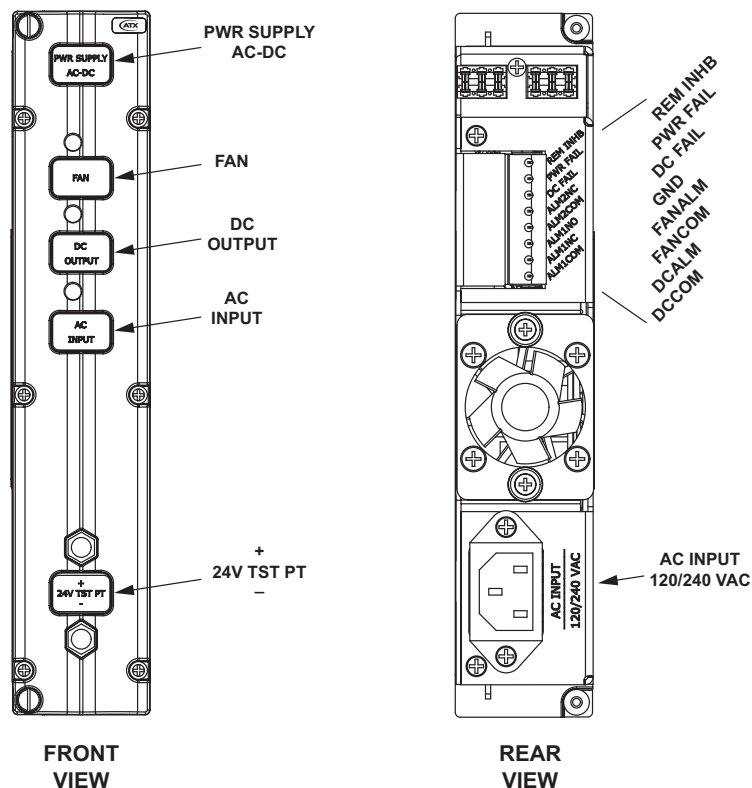

Figure #6: 100/120/240 VAC Power Supply

100/120/240 VAC and  $-48$  VDC power supplies each have remote inhibit, power fail, and a pair of alarm contacts. Connections are made via a screw terminal connector on the rear panel. In the case of power supply fan failure, replacement fan kits are available from ATX Networks.

One AC/DC or DC/DC power supply can power up to 9 amplifiers. In the 5RU chassis, an option to power eight amplifiers with redundant load-sharing power supplies is available. In the 2RU chassis, an option to power two amplifiers with redundant load-sharing power supplies is available.

On the 5RU chassis a power strip (backplane) connects the power supply to the amplifiers. This backplane is part of a trough with connectors.  $+24$  VDC from an external source may be connected to a connector located on the power strip and 10 amplifiers may be installed in the 5RU chassis. Power strip is affixed to the rear side of the chassis and runs lengthwise across the top.

On the 2RU chassis a power kit connects the power supply to the amplifiers.  $+24$  VDC from an external source may be connected to a connector located on the power kit and four amplifiers may be installed in the 2RU chassis. Power kit is affixed to the rear center of the chassis.

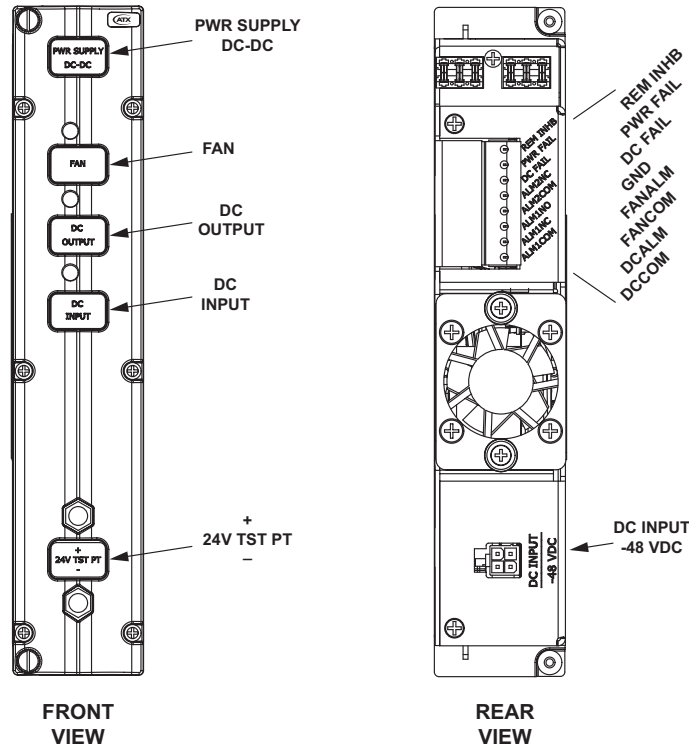

Figure #7: -48 VDC Power Supply

### 2.2.1. Power Supplies

The SignalOn power supplies use either 100/120/240 VAC or -48 VDC input power. AC/DC or DC/DC power supplies include circuitry for the detection of a power supply failure. Alarm contacts are located on the rear panel of the power supply module. These contacts support existing customer-supplied alarm systems. The DCALM contact is used to indicate DC power failure. FANALM is used to indicate fan failure.

When power supply output drops below 18 VDC from its nominal value of 24 VDC the relay circuitry closes a switch completing an external alarm circuit, resulting in an alarm.

### 2.2.2. A/B Redundancy

Power distribution backplane automatically accommodates power redundancy and load sharing when two power supplies are inserted into any chassis position. If one power supply fails the other power supply picks up the entire load.

# PLANNING

## 3. Planning

Several things need to be considered when planning for the location of the SignalOn Series chassis. Some of these are:

- Chassis should only be installed in restricted access areas (dedicated equipment rooms, equipment closets, cabinets, etc.) in accordance with Articles 110-16, 110-17, and 110-18 of the National Electrical Code, ANSI/NFPA 70.
- When using open relay-rack style network bays, spacing between bays and at lineup ends may be required depending on the quantity and type of coaxial cable entering the bays. When spacing bays 0, 5, or 10 inches, verify that vertical jumper rings will fit between bays.
- Allow sufficient room for cable management behind each chassis. Also leave sufficient vertical and horizontal cable pathways above and below the chassis.
- Determine voltage source to be used AC, –48 VDC, or +24 VDC.



**Caution:** *Power supplies are designed to power a maximum of ten forward path amplifiers. Powering more than ten amps may result in amplifier failure.*

### 5RU Considerations

- ATX Networks does not recommend daisy-chaining 5RU chassis together.
- A fully loaded passive chassis may terminate up to two-hundred cables. Consideration should be given to the number of chassis installed in a rack to prevent cable congestion.
- When installing power supplies consider the RF cabling requirements, i.e. left, right, or both sides for vertical cable runs.
- When using redundant power in the 5RU chassis, consideration should be given to install power supplies in adjoining slots.
- Power supplies may be installed in any slot depending upon the specific application. RF cabling is less congested if power supplies are installed in the center of the 5RU chassis.

### 2RU Considerations

- When using redundant power in the 2RU chassis, power supplies must be installed in the same chassis.
- Up to three 2RU chassis may be daisy-chained together powering a maximum of ten amplifiers using DC–DC power supply, or AC–DC power supply.

### 3.1. Cooling Considerations

A fully loaded chassis generates a significant amount of heat. The following guidelines should be followed when installing these products:

- Allow at least one rack space between each 2RU chassis.
- See Figure 8 for recommended fully loaded 2RU chassis spacing.
- If stacking three 5RU chassis a fan pack must be installed between the first and second chassis.
- If a fan pack is not used, allow 10 rack spaces (minimum) between each two consecutive 5RU chassis within a rack.
- See Figure 9 for recommended fully loaded 5RU chassis spacing.

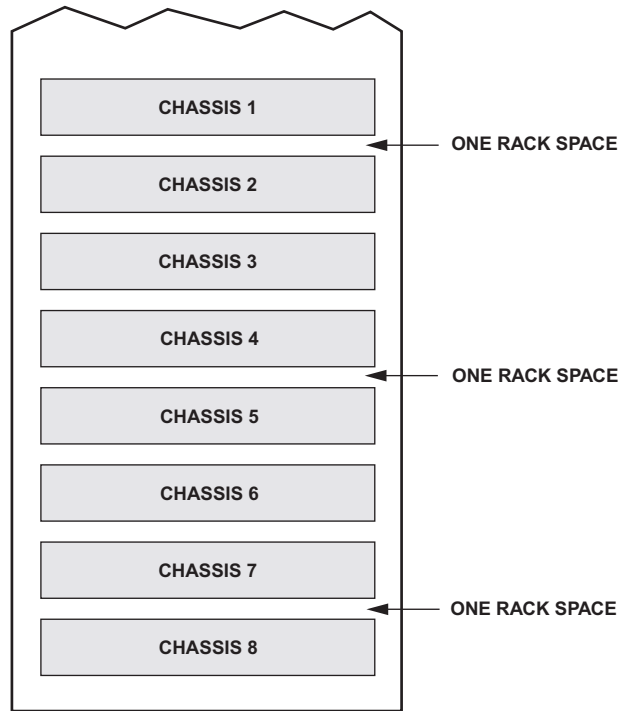

Figure #8: Recommended Fully Loaded 2RU Chassis Spacing

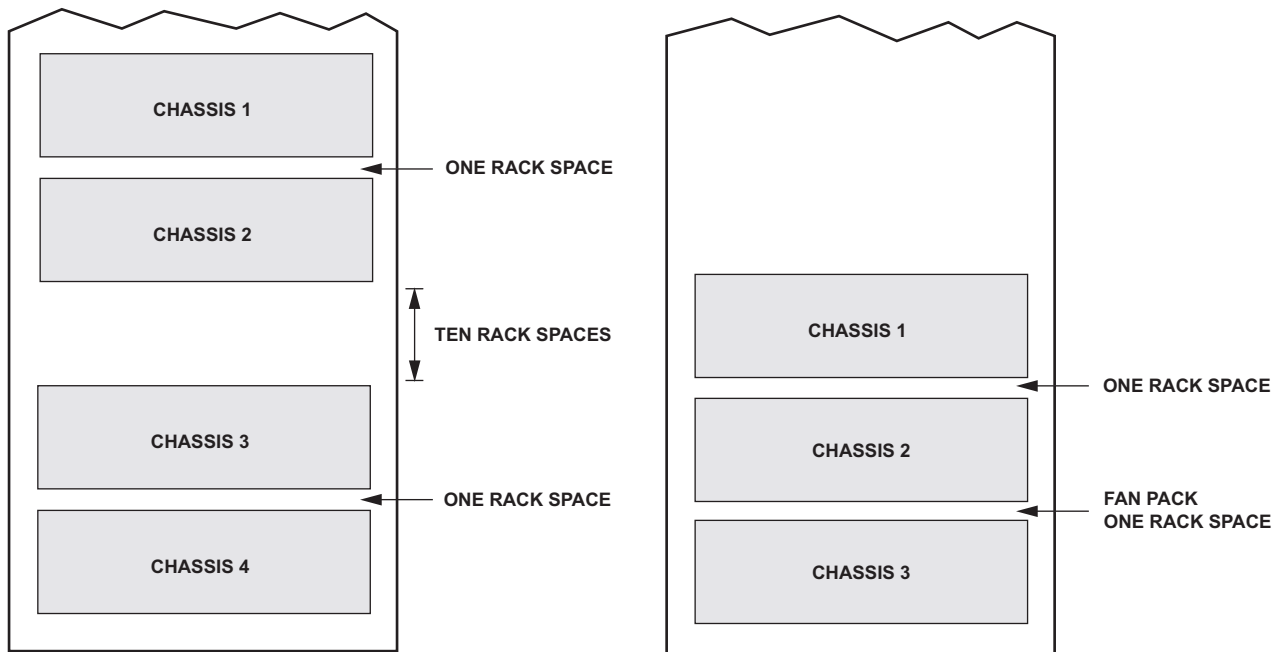

Figure #9: Recommended Fully Loaded 5RU Chassis Spacing

# INSTALLATION

## 4. Installation

### 4.1. Chassis Installation



**Warning:** *Never install equipment in a wet location or during a lightning storm.*

This section provides the procedures necessary for installing and cabling the SignalOn Series chassis in a 19-inch equipment rack. Optional extension brackets are available for installation in 23-inch rack applications.

Use the following procedure to install chassis in a 19-inch network rack, or equivalent.

1. Obtain a Flat blade or Phillips screwdriver (type to match mounting screws).
2. Place the chassis in the assigned mounting space and align the holes in the mounting brackets with the holes in the equipment rack. See Figure 10 or Figure 9.
3. Secure mounting brackets to the equipment rack using the 12-24 x 0.5-inch binder head machine screws provided. Torque these screws to approximately 27 pound-inches (3.1 Newton meters).
4. Install power supply strip/kit following the installation drawing provided. Power strip/kit is affixed to the rear of the chassis.

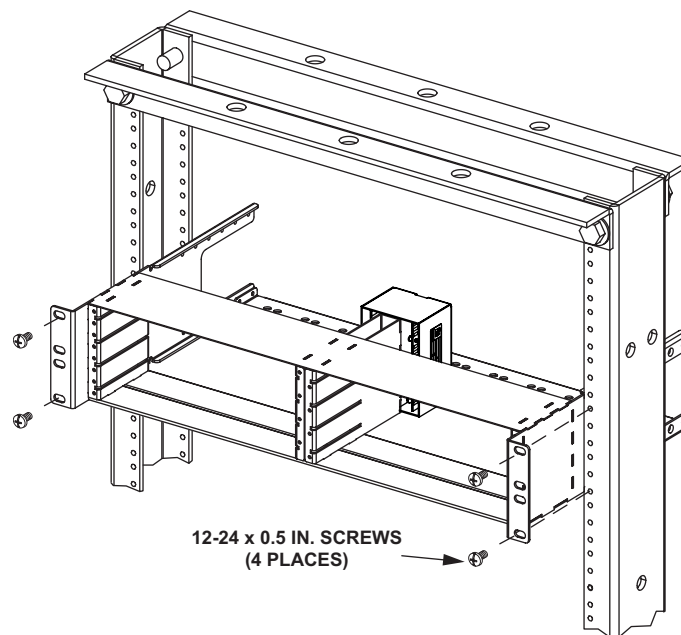

Figure #10: Installing 2RU Chassis in Rack

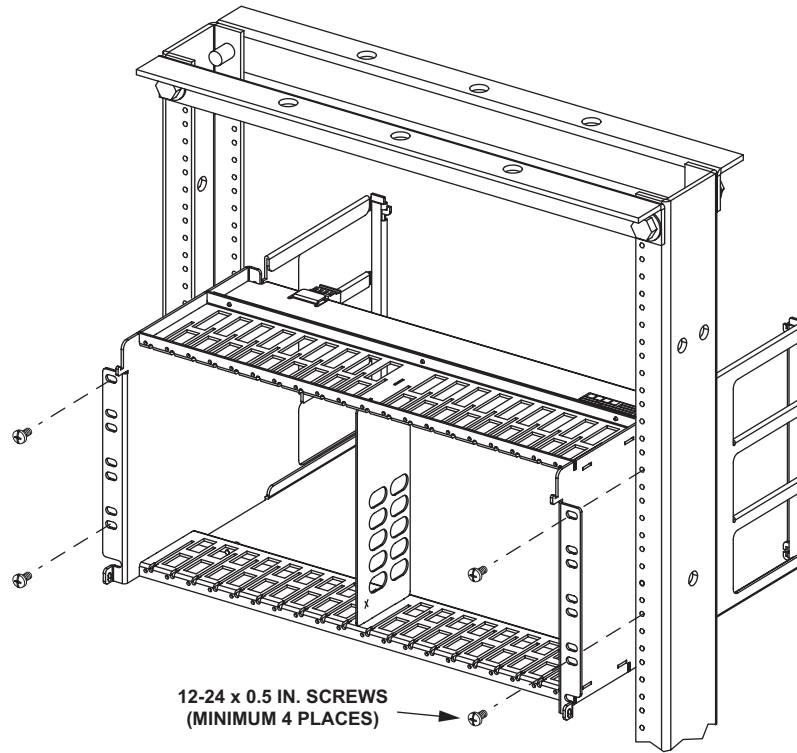

Figure #11: Installing 5RU Chassis in Rack

## 4.2. Connect Chassis Ground

This procedure establishes a ground connection between the chassis and the frame ground connection. A frame ground termination (#8 screw) is provided on the back of the 2RU chassis, for a frame ground connection. See Figure 12.

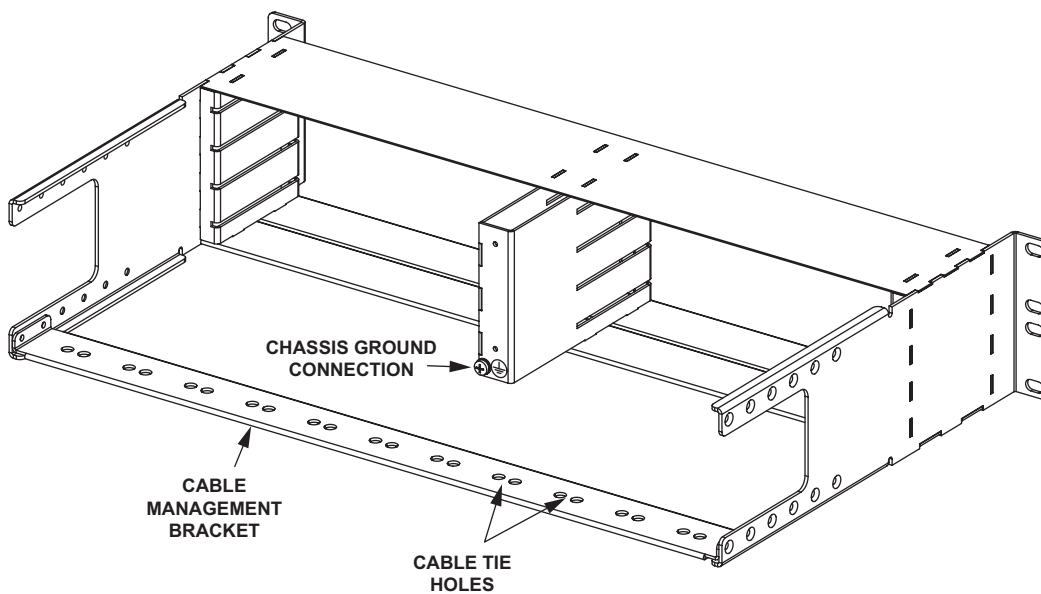
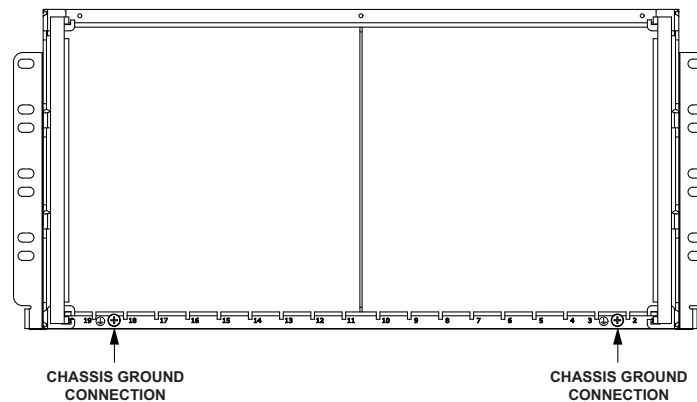

Figure #12: 2RU Chassis Ground Connection (Rear View shown without Power Kit)



Two frame ground terminations (#8 screw) are provided on the back of the 5RU chassis, for a frame ground connection. See Figure 13. This connection must be made in accordance with all local and national electrical codes.



**Figure #13: 5RU Chassis Ground Connection (Rear View)**

1. Using AWG 16 (or larger) stranded wire, connect frame ground using the FRM GND screw(s) located on the rear panel of the chassis and tighten the screw securely.
2. To assure proper operation the Frame Ground stud should be connected to a good earth ground through the local grounding system.
3. Connect the other end of the ground wire to the office ground conductor. Ensure this connection is made using methods and hardware that meets all applicable local and national electrical codes.

### 4.3. Installing Power Supply Modules in 5RU Chassis

Each power supply occupies two slots in the chassis. Use the following procedure to install power supply in the vertical chassis:

1. Power supplies may be installed in any slot. RF cabling practices may dictate which slots power supplies are installed in. See Figure 14.
  - a. If routing RF cables to both the right and left, power supplies should be installed in chassis slots (9/10 and 11/12).
  - b. If routing RF cables to the right, power supplies should be installed in chassis slots (1/2 and 3/4).
  - c. If routing RF cables to the left, power supplies should be installed in chassis slots (17/18 and 19/20).
2. Make sure the ATX logo (or any other front panel lettering) is readable. Align the power connector at the top of the power supply with the power connector in the chassis. Slide the power supply into its designated location in the chassis.

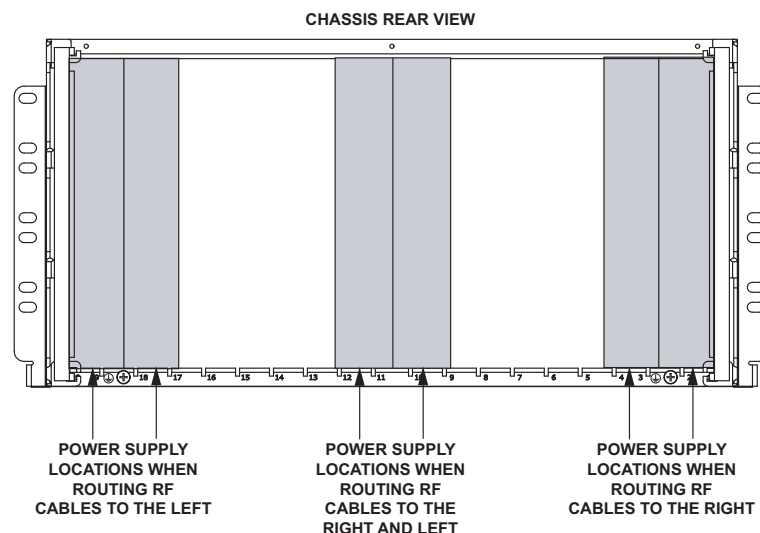

**Figure #14: Power Supply Location 5RU Chassis**

3. Secure power supply using the two captive retaining screws. See Figure 15.

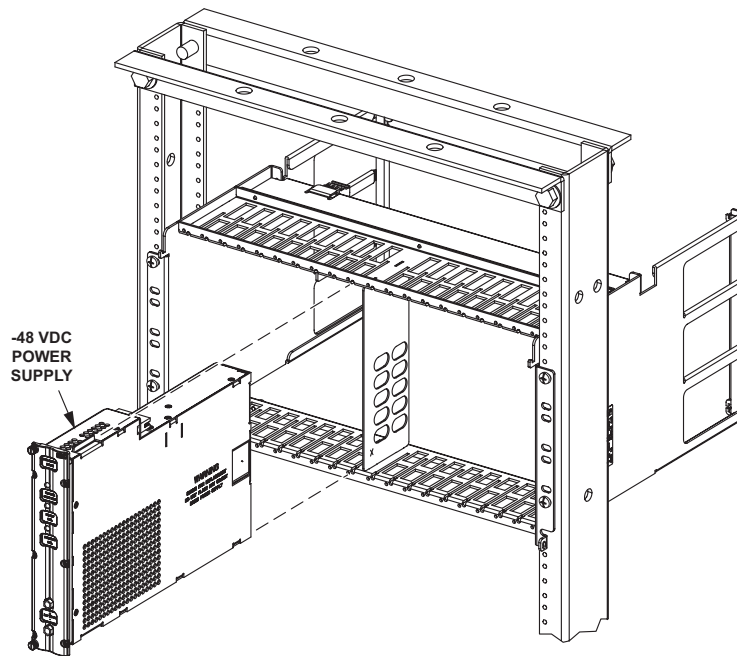

Figure #15: Power Supply Module Installation (5RU Chassis)

4. Repeat the procedure for the other power supply module (if any).
5. Repeat this procedure for each chassis.

#### 4.4. Installing Power Supply Modules in 2RU Chassis

Each power supply occupies two slots in the chassis. Use the following procedure to install power supply in the horizontal chassis:

1. Power supplies may be installed in any slot. RF cabling practices may dictate which slots power supplies are installed in.  
**NOTE:** When installing power supplies in the lower two slots of the 2RU chassis move the cable management bracket to the top of the chassis.
2. Make sure the ATX logo (or any other front panel lettering) is readable. Align the power connector at the top of the power supply with the power connector in the chassis. Slide the power supply into its designated location in the chassis. See Figure 16.
3. Secure power supply using the two captive retaining screws.
4. Repeat the procedure for the other power supply module (if any).

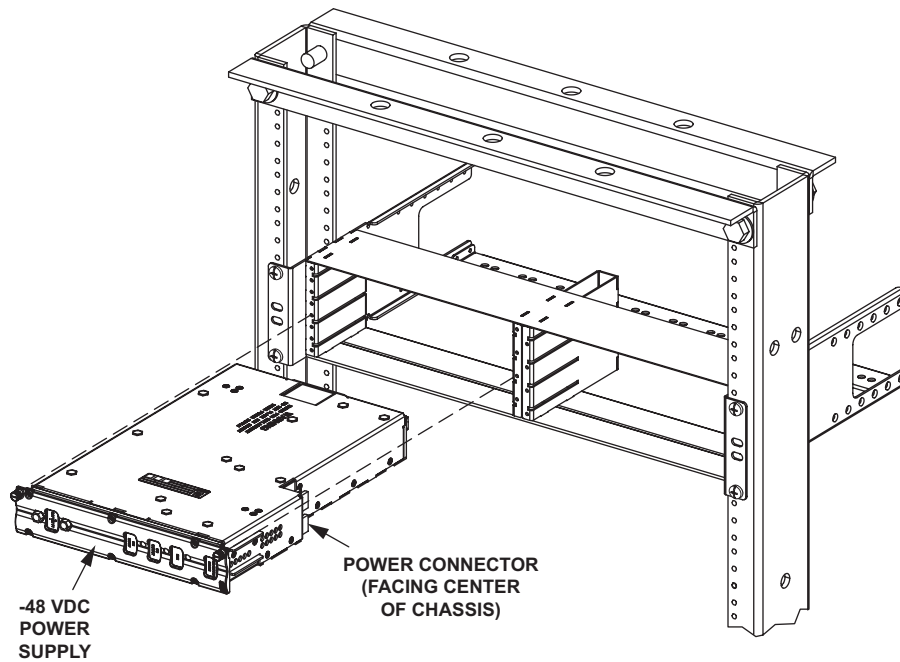

Figure #16: Power Supply Module Installation (2RU Chassis)

#### 4.5. Install 5RU Chassis Door

The door is installed on the front of chassis and pivots on two hinge points located on the lower outside corners. Each hinge point goes into a slotted hole on each side of chassis. Once installed, the door is raised and latches on two short extensions at the front of the chassis. To install door:

1. Grasp the door (inside facing up) with both hands. See Figure 17.
2. Place your thumbs towards the center of the door.
3. Gently push down with your thumbs while holding the ends of the door with your fingers.
4. Slide hinge pin on one end of the door into the slot on that end. At the same time slide the other hinge pin on the other end of the door into the slot at that end.
5. Release the downward pressure on the door, the door will straighten out and slide into the hinge slots in the chassis.

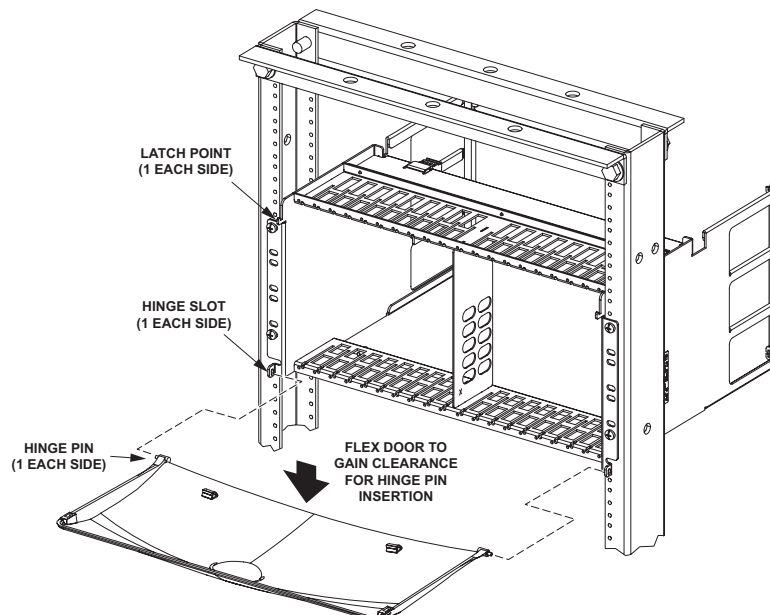

Figure #17: Door Installation (5RU Chassis)

### 4.6. Install Designation Card (5RU Chassis)

Slide designation card into plastic hinges mounted on the back of the door, see Figure 18. Designation card should be visible from the front of the chassis when door is open. Flip designation card over before closing door, cable designations are now visible when door is closed.

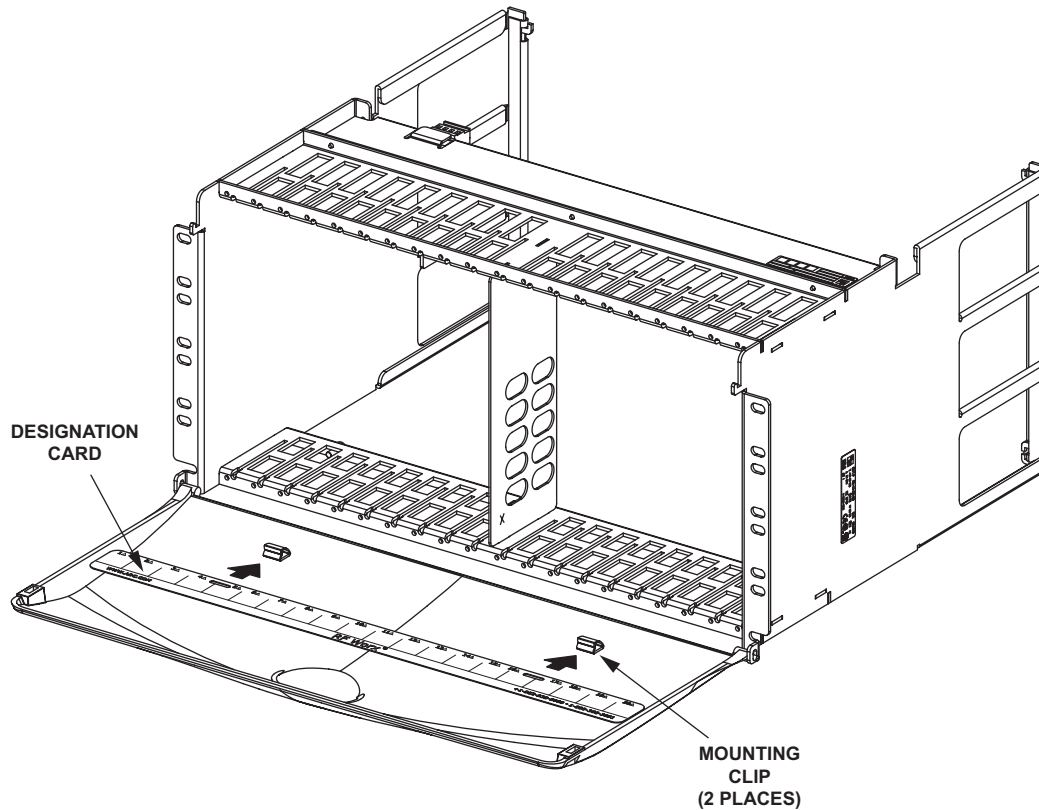

Figure #18: Designation Card Installation (5RU Chassis)

### 4.7. Alarm Connections

The AC/DC and DC/DC power supplies include circuitry for the detection of power supply failures. DCALM is a set of relay contacts for the DC power alarm. This is a normally closed contact. There are also three logic alarm terminals on the back of each power supply; REM INHIB (Remote Inhibit), PWR FAIL (AC OK), and DC FAIL (DC OK). These may be connected to an RS232 interface for alarm monitoring.

Connect any pre-existing alarm system to the contacts on the rear of the power supply modules as shown in Figure 19. When using +24 VDC customer supplied power there are no alarm contact points. See Table 1 for alarm terminal defaults.

**NOTE:** Alarm circuit contacts are in the alarm state when there is no power to the chassis.

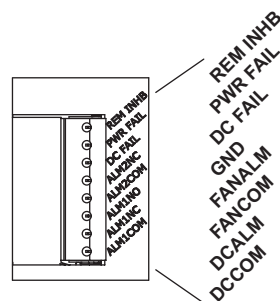

Figure #19: Alarm Contact Connections

ALARM	DEFAULT	APPLICATION
REMINHB	Low	Apply high to disable (TTL).
PWR FAIL	High	Goes low to indicate power IN failure (TTL).
DC FAIL	High	Goes low to indicate DC OUT failure (TTL).
GND	- - -	Ground for TTL levels.
FANALM	Normally open	Closes when fan fails.
FANCOM	Common	Common contact for Fan.
DCALM	Normally closed	Opens when module has power applied, closes to indicate loss of power.
DCCOM	Common	Common contact for DCALM.

Table #1: Alarm Terminal Defaults

## 4.8. Power Connections

### 4.8.1. AC Power Connections

Power cord supplied is a U.S. NEMA 5-15P for international use. Terminate power cord according to the country of origin. Plug one end into the power supply and the other end into the AC outlet. If using two AC/DC power supplies, repeat this procedure for the other power supply.

### 4.8.2. DC Power Connections

**Caution:** *When connecting the equipment to the power sources, check the equipment nameplate rating to avoid overloading circuits which may cause damage to over-current protection devices and supply wiring.*

#### 4.8.2.1. Connect –48 VDC Power

**Warning:** *Before making any power connections to the chassis, verify that the power is off (fuse removed at the fuse and alarm panel) and that the plug-in module is removed from the chassis. Do not install plug-in module until after the chassis power wiring is completed.*

An accessible disconnect device and protective device must be provided in the fixed wiring for a DC power supply. It must also be suitable for the rated voltage and specified current. The disconnect and protective device should be rated at a maximum of 7.5 Amps. A and B power feeds are for redundant power sources. The chassis will operate with only one power source. This procedure describes how to connect the –48 VDC to the chassis.

- Obtain the items listed below:
  - Wire stripper
  - Screwdriver
- Plug DC power cord provided into power supply. Make certain that the retainer latches. Identify and label the ends of the two power supply wiring pairs with the following designations:
  - BAT, RTN
- Route each pair of power supply wires to separate power sources and cut to length, allowing sufficient length for termination. Separately fuse each power source (–48 VDC) but do not install fuses at this time. Recommended fuse size is 7.5 amps.
- Dress and secure the wires to the chassis and rack following local practice. Route wiring away from sharp edges and secure in place to prevent chaffing and provide strain relief.
- Strip 0.5-inch (1.27 cm) of insulation from the end of each wire.
- Terminate power supply wires with the appropriate terminals for the fuse panel.
- Secure wires to the appropriate power supply terminal location.
- Install fuses in the fuse holders.

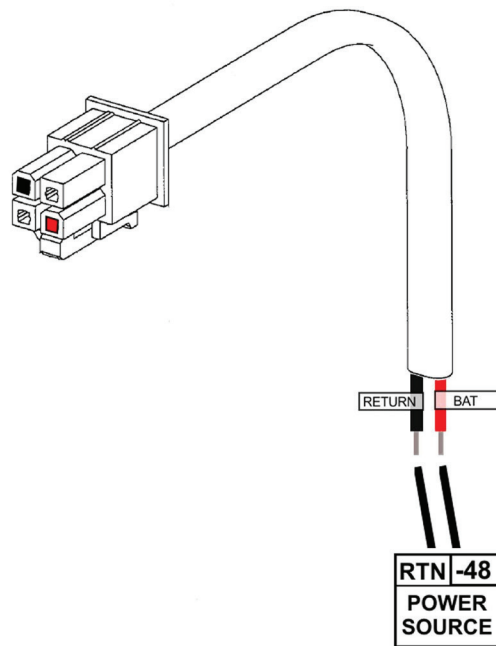

Figure #20: N-ACC-CBL-DC-DC Power Cable for N-MV48DC SignalOn -48 VDC Power Supply

#### 4.8.2.2. Connect +24 VDC Power

The SignalOn Series chassis may be powered by connecting +24 VDC directly to the power strip installed on the rear of the chassis. A four position terminal block is provided for connecting the power wires. See Figure 21 or Figure 22 for +24 VDC terminal block location.



**Caution:** A maximum of ten forward path amplifiers may be powered with +24 VDC customer supplied power, from any single chassis.

1. Route a pair of power supply wires from the chassis to the power source and cut to length, allowing sufficient length for termination. Fuse power source but do not install fuse at this time. See Section 8, Specifications for recommended fuse size.
2. Dress and secure the wires to the chassis and rack following local practice. Route wiring away from sharp edges and secure in place to prevent chaffing and provide strain relief.
3. Strip 0.5-inch (1.27 cm) of insulation from the end of each wire.
4. Insert one end of each wire into the four position terminal block, one into the +24 VDC-IN position and the other into the RTN position. Tighten retaining screws.
5. The terminal block must plug into the four-pin receptacle on the back of the chassis. Torque terminal block screws to approximately 5 pound-inches (0.5 Newton meters).
6. Terminate other end of power supply wires with the appropriate terminals for the fuse panel.
7. Secure wires to the appropriate power supply terminal location.
8. Install fuses in the fuse holder.

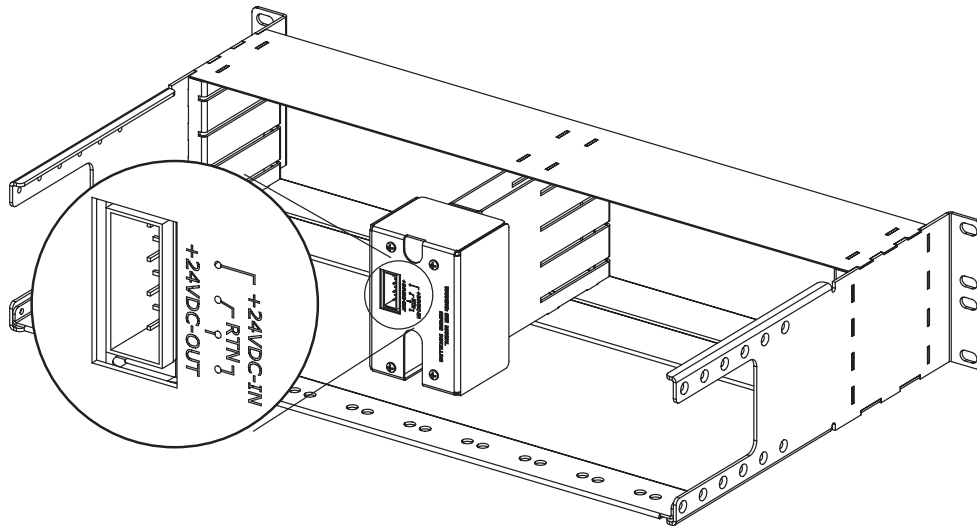

Figure #21: +24 VDC Terminal Block Location (2RU Chassis)

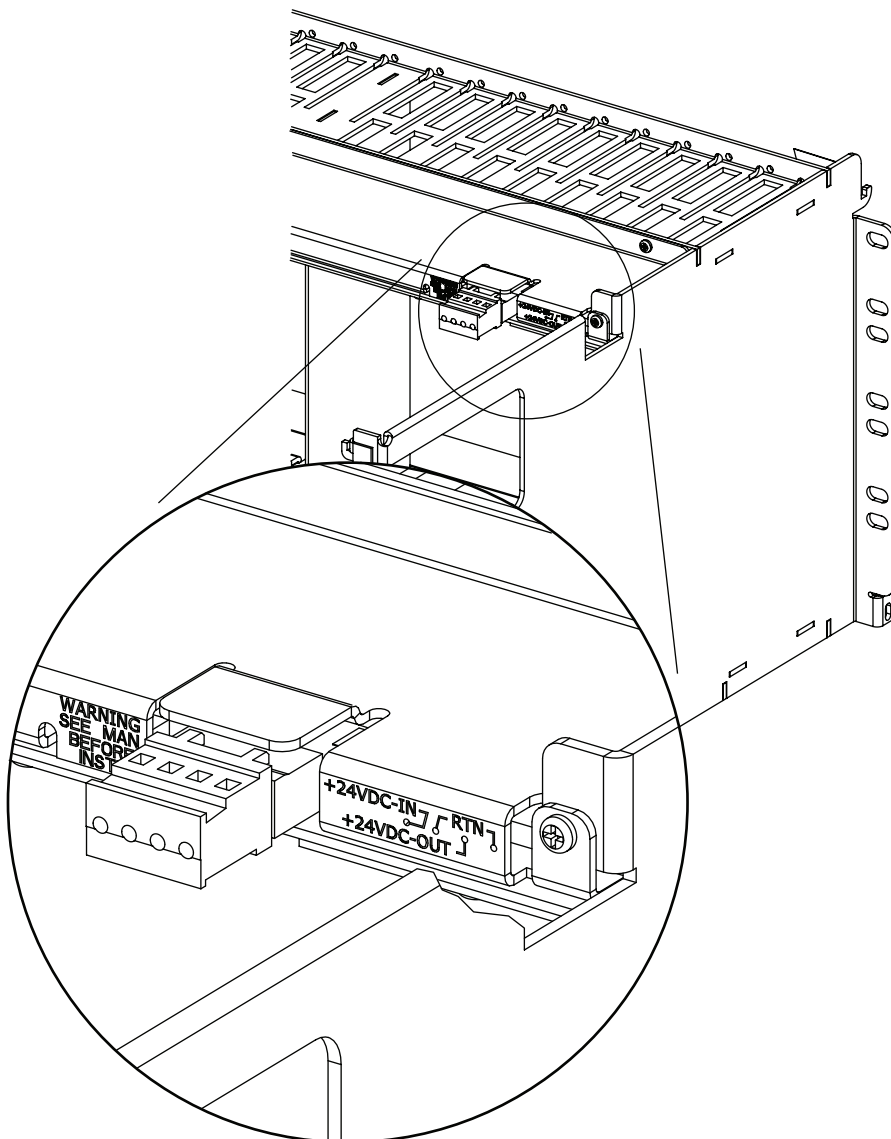

Figure #22 +24 VDC Terminal Block Location (5RU Chassis)

This page left intentionally blank.



# CABLE MANAGEMENT

## 5. Cable Management

### 5.1. 5RU 20-Position Chassis Cabling

#### 5.1.1. Cabinet Considerations

1. Cable the uppermost chassis first; route the cables through the top cable ring closest to the front of the cabinet. Cables from the next-lower chassis exit the cabinet through the next top cable ring toward the rear of the cabinet.
2. Route the cables from the two lowest chassis through the cable rings at the middle of the cabinet then through the two rearmost rings at the top of the cabinet.

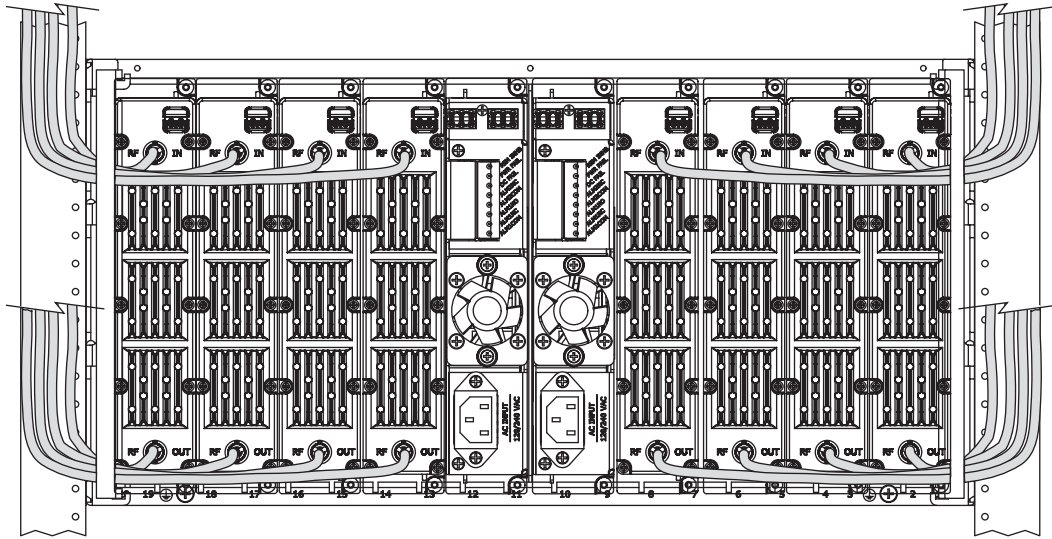

Figure #23: Fully Loaded Chassis with 8 Forward Path Amplifiers and 2 AC Power Supplies (Power Strip Removed for Clarity.)

#### 5.1.2. Module Cabling Considerations

1. Within a given chassis, cable outer modules first; i.e., Modules 1 and 19, 3 and 17, 5 and 15, then 7 and 13. Keep cables in a horizontal plane as shown in Figure 23 and route them through the side access slots on the side of the chassis. Route cables from Modules 3–7 up the inside of the right side panel (as viewed from the rear), and route the cables from Modules 13–19 up the inside of the left side panel (as viewed from the rear).
2. Keep all Module-to-Module wiring in the same horizontal plane.
3. To help prevent cable congestion Module-to-Module cabling to different ports in the same chassis should go OUT the side access slots, then back through another access slot at the same level as the second port. Cabling from one chassis to another should also be routed through the side access slots.
4. Install cable retainer bars on each side of the chassis.

### 5.1.3. General Considerations

Route all cables through the side access slots before routing them through the cable management rings at the top of the cabinet (or middle and top of cabinet, as in Figure 24). All cables must exit the rack through the 4-inch by 4-inch rings at the top of the cabinet. 4 x 4 cable rings are not included with the SignalOn chassis or modules.

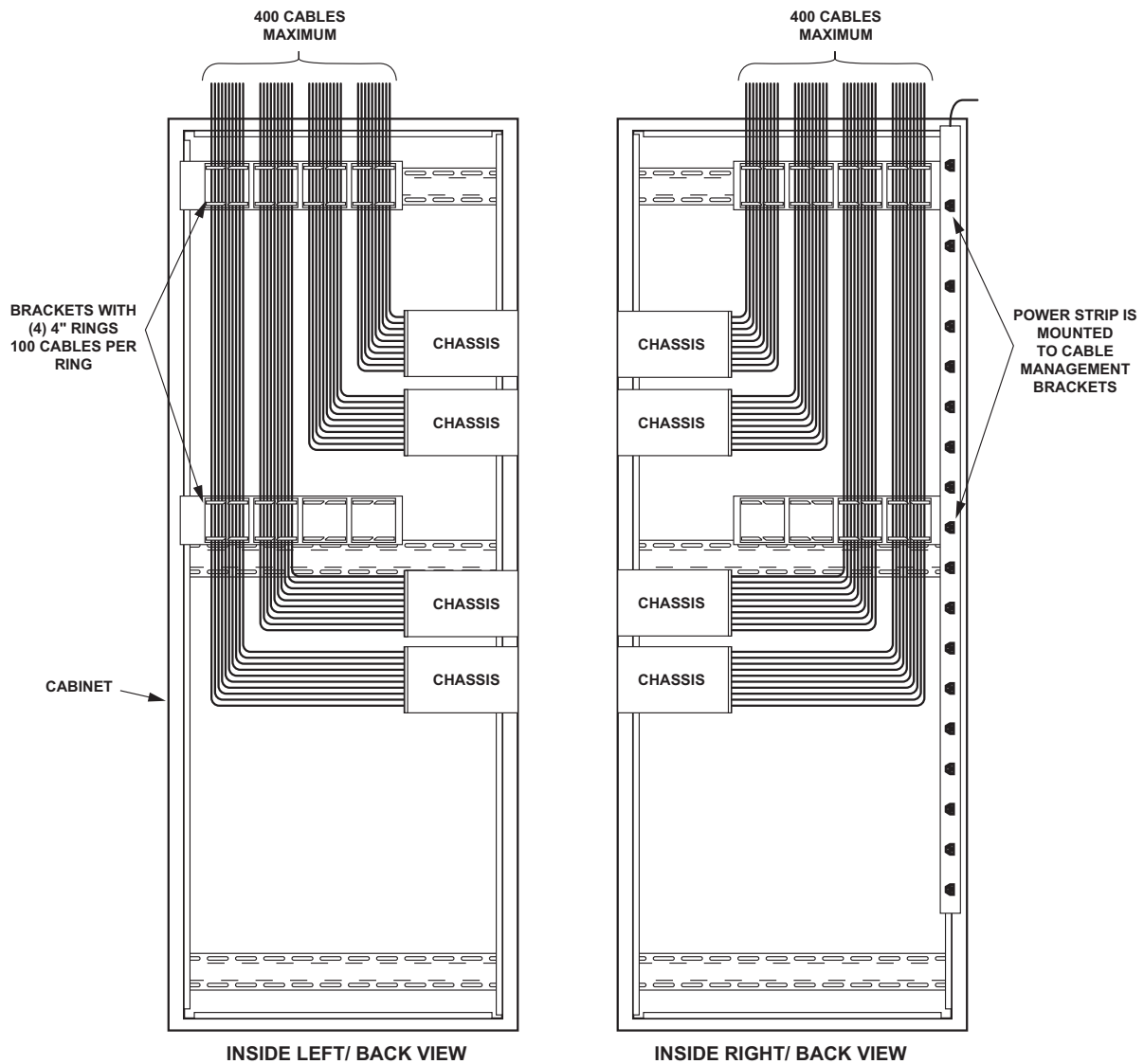

Figure #24: Cable Ring Usage

## 5.2. 2RU 8-Position Chassis Cabling

The 2RU chassis has an optional adjustable cable management bracket. The bracket can be moved forward or back to allow for the desired cable bend radius. To move the cable management bracket remove the two screws on each side and slide the bracket to the desired position. Insert and tighten the screws removed earlier. Holes are provided in the cable management bracket for cable ties. See Figure 25.

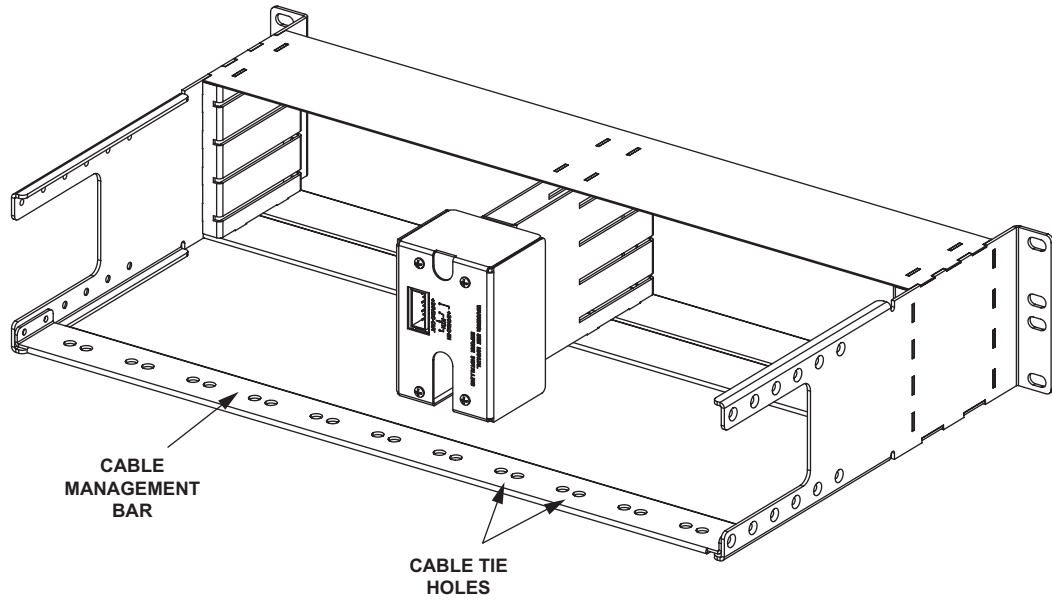

Figure #25: 2RU Chassis Cable Management Bracket

This page left intentionally blank.

# OPERATING INSTRUCTIONS

## 6. Operating Instructions

### 6.1. Power Supply

The power supply front panel has LEDs to indicate fan and power conditions and a test point to verify the +24 VDC. There are three LED indicators on the power supply front panel. Refer to Table 2 for a functional description of each indicator and the test point. The location of the indicators and test point is shown in Figure 26.

INDICATOR	COLOR	DESCRIPTION
FAN FAIL	Green	Fan fail alarms (green to red) on fan failure. Continues to operate (Green) if current shared with another power supply.
	Red	Fan failure.
DC OUT FAIL	Green	Operating properly.
	Off	No DC power output to the chassis backplane.
POWER IN FAIL	Green	Operating properly.
	Off	No input power present.
24V TST PT	N/A	+24 VDC measured between + and - jacks.

Table #2: Front Panel Indicators and Test Point

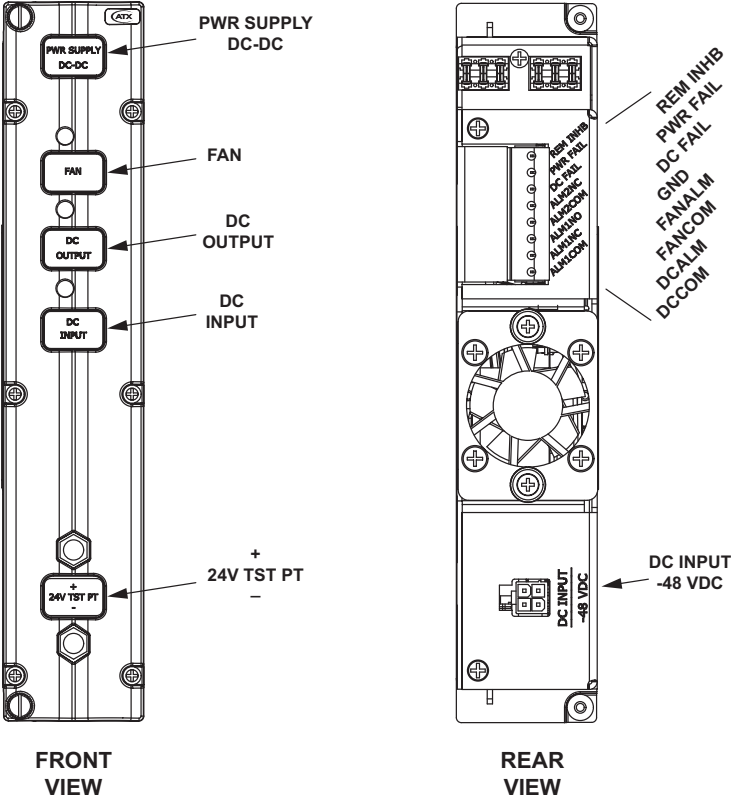

Figure #26: -48 VDC Power Supply

This page left intentionally blank.

## MAINTENANCE

### 7. Maintenance

Maintenance requirements for the SignalOn series chassis and power supply covered in this manual are minimal, consisting merely of periodic surface cleaning and fan filter cleaning.

The outside of the chassis and components should be cleaned during routine office equipment maintenance. Care must be taken to prevent dust and dirt from getting into any of the coaxial jacks or connectors.

#### 7.1. Power Supply Fan Replacement Procedure

Each power supply module is equipped with a rear cooling fan that draws air in and pushes it through the power supply module. The heated air is then exhausted through vent holes on the power supply module. This method of cooling is preferred so that airborne contaminants are caught on the outside of the fan filter. This reduces dust buildup on the fan blades, as well as internally in the power supply. Over time, dust and airborne contaminants can cause the air filter to become blocked. The time it takes for the filter to get sufficiently blocked is dependent on the environment that the unit operates in.

Due to the same environmental conditions, fan bearings may also wear out. This results in the red “FAN FAIL” LED to illuminate on the front of the module as shown in Figure 27. The fan assembly is a field replaceable component. Catalog number for the fan replacement kit is: N-ACC-FAN-01 (with filter) or N-ACC-FAN (without filter). Please note that these fans are not compatible with each other so be sure to order the correct replacement depending on the device purchased. Older units do not have filters (visible from outside). The fan replacement kit may be purchased through your local distribution channel, or ATX Networks. Fan replacement may be performed while power supply is in service, or out of service.

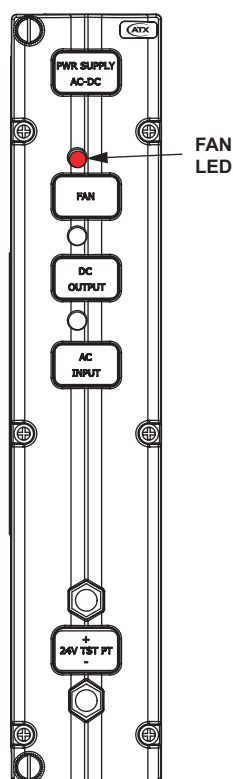

Figure #27: AC Power Supply (Front View)

Use the following procedure to replace cooling fan:

1. Carefully move any cables away from the rear of the power supply that may be blocking fan.
2. Loosen the two thumbscrews that secure the fan assembly to the power supply module. See Figure 28.
3. Carefully withdraw fan assembly from power supply module until the wiring harness is exposed and connector is accessible.
4. Depress latch release on the fan connector and unplug the connector from the connector on the wiring harness.
5. Plug new fan connector into the wiring harness connector.
6. Carefully push fan wiring and connector back into the power supply module making certain no to pinch or break the fan wires.
7. Position fan assembly in the module and tighten thumbscrews.
8. If a fan failure caused the power supply to overheat and shut down, the power supply input voltage must be cycled. For DC primary powered systems, remove the primary fuse feeding the SignalOn chassis from the BDFB fuse panel and reinsert. For AC primary powered systems, remove and replace AC power cord connection from AC socket located on the rear of the power supply.
9. Verify that the power supply starts, LED status for input and output voltage and fan are green, and that the fan is operating properly.
10. Verify that all active modules located in the chassis are powered up and operational.
11. Re-tie any cables moved away from rear of the power supply module.

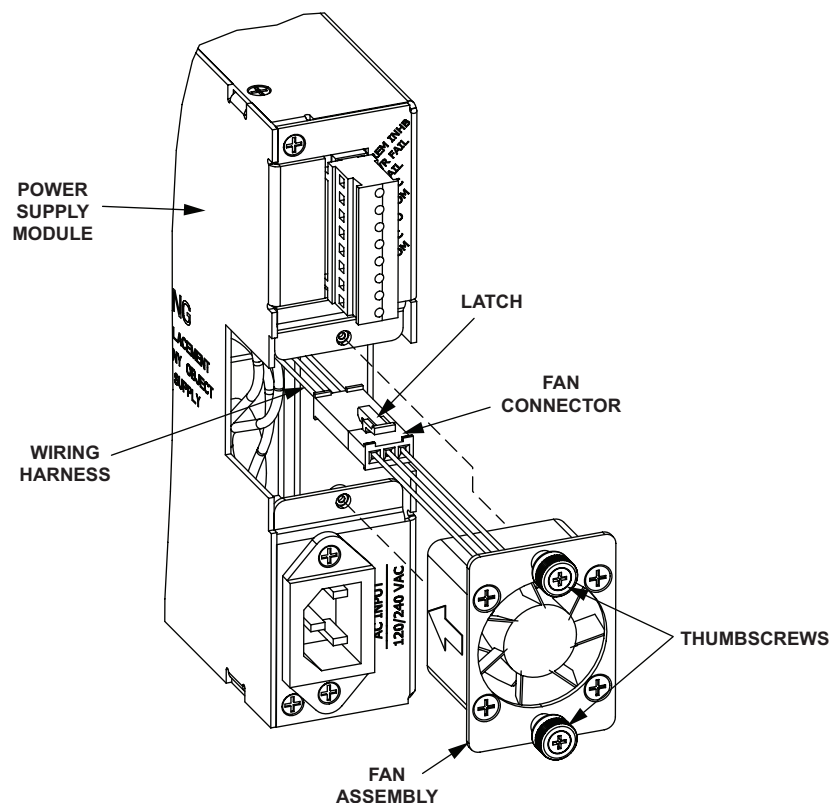

Figure #28: Power Supply Fan Replacement



## 7.2. Preventative Actions

1. Regularly change facility air handling equipment filters every 30-60 days.
2. Stock a 1% spares inventory of fan assemblies to facilitate quick field repairs.
3. Develop a maintenance plan for periodic visual inspection, and cleaning of the fan filters.

## 7.3. Cooling Fan Maintenance

Maintenance of the power supply cooling fan is a simple procedure that is quickly accomplished in usually less than 5 minutes.

1. Carefully move any cables away from the rear of the power supply that may be blocking fan.
2. Loosen the two thumbscrews that secure the fan assembly to the power supply module. See Figure 28.
3. Carefully withdraw fan assembly from power supply module by pulling straight back until the wiring harness is exposed and the connector is accessible.
4. Depress latch release on the fan connector and unplug the fan connector from the connector on the wiring harness.
5. Holding the fan assembly, use compressed air to blow the dirt & dust particles out of the fan filter by first blowing the air through the fan assembly from the inside to outside. Next, use compressed air to blow off dirt particles on the external side of the fan assembly.
6. An alternative to Step 5 would be to use a small shop vacuum cleaner to remove dirt & dust from the external side of the filter.
7. Once the fan assembly has been thoroughly cleaned, re-insert the fan assembly into the power supply module using Step 5 through Step 11 in the fan replacement procedure in this section.

**NOTE:** Depending on the environmental conditions and the location of where this equipment operates, power supply may overheat and cause a thermal shut down if proper air flow is not supplied to the module. Do not allow power supplies to operate without a fan assembly for any extended period of time.

For any other repairs, contact ATX Networks at the telephone number listed in Section 9, Service & Support, of this manual.

This page left intentionally blank.

# SPECIFICATIONS

## 8. Specifications

Please refer to the SignalOn chassis datasheet and the SignalOn power supply data sheet located at [atx.com](http://atx.com) for specifications.

This page left intentionally blank.

# SERVICE & SUPPORT

## 9. Service & Support

### 9.1. Contact ATX Networks

Please contact ATX Technical Support for assistance with any ATX products. Please contact ATX to obtain a valid RMA number for any ATX products that require service and are in or out-of-warranty before returning a failed module to ATX.

#### TECHNICAL SUPPORT

Tel: 289.204.7800 – press 1  
Toll-Free: 866.YOUR.ATX (866.968.7289) USA & Canada only  
Email: [support@atx.com](mailto:support@atx.com)

#### SALES ASSISTANCE

Tel: 289.204.7800 – press 2  
Toll-Free: 866.YOUR.ATX (866.968.7289) USA & Canada only  
Email: [insidesales@atx.com](mailto:insidesales@atx.com)

#### FOR HELP WITH AN EXISTING ORDER

Tel: 289.204.7800 – press 3  
Toll-Free: 866.YOUR.ATX (866.968.7289) USA & Canada only  
Email: [orders@atx.com](mailto:orders@atx.com)  
Web: [www.atx.com](http://www.atx.com)

### 9.2. Warranty Information

All of ATX Networks' products have a 1-year warranty that covers manufacturer's defects or failures.

### 9.3. Safety

#### IMPORTANT! FOR YOUR PROTECTION, PLEASE READ THE FOLLOWING:

**WATER AND MOISTURE:** Care should be taken so that objects do not fall and liquids are not spilled into the enclosure through openings.

**POWER SOURCES:** The device should be connected to a power supply only of the type described in the operating instructions or as marked on the device.

**GROUNDING OR POLARIZATION:** Precautions should be taken so that the grounding or polarization means of the device is not defeated.

**POWER CORD PROTECTION:** Power supply cords should be routed so that they are not likely to be pinched by items placed upon or against them, paying particular attention to cords at plugs, convenience receptacles, and the point where they exit from the device.

**SERVICING:** The user should not attempt to service the device beyond that described in the operating instructions. All other servicing should be referred to qualified service personnel.

**FUSING:** If your device is equipped with a fused receptacle, replace only with the same type fuse. Refer to replacement text on the unit for correct fuse type.



© 2020 by ATX Networks Corp. and its affiliates (collectively "ATX Networks Corp.").  
All rights reserved. This material may not be published, broadcast, rewritten, or  
redistributed. Information in this document is subject to change without notice.

Rev. 01/20 (ANW1149)



**ATX Networks**

Tel: 289.204.7800 | Toll-Free: 866.YOUR.ATX (866.968.7289) | [support@atx.com](mailto:support@atx.com)

[www.atx.com](http://www.atx.com)